

1220mm x 675mm clear opening multiple ductile iron cover (B125) bedded on a gauged Class 1 (3:1) sand/cement mortar to Cl.2402 of SHW Mortar Designation (i)

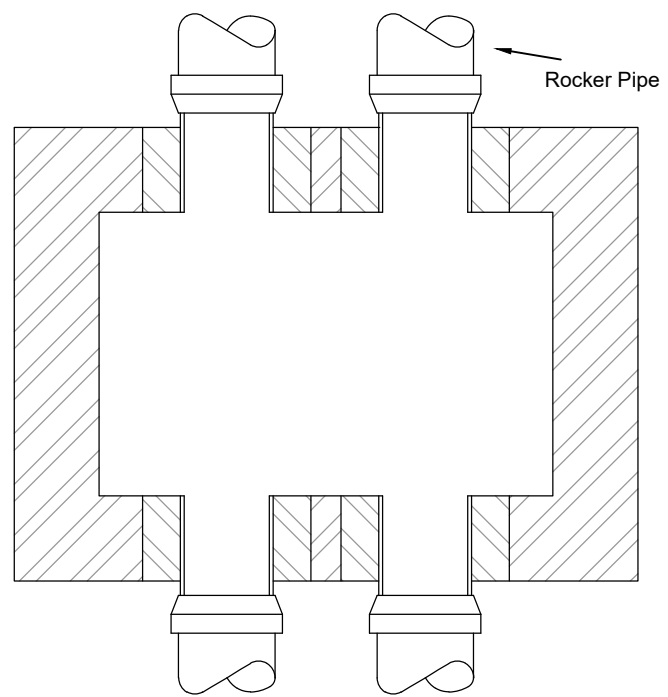
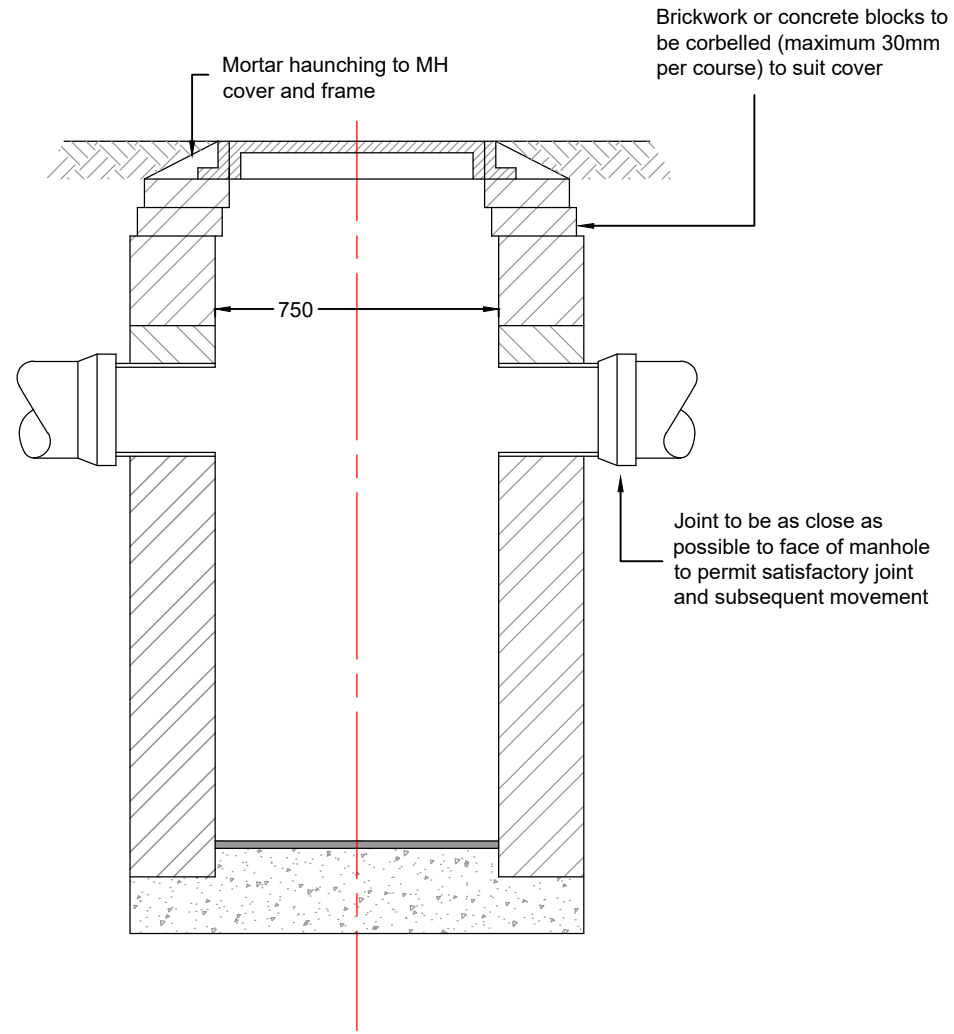
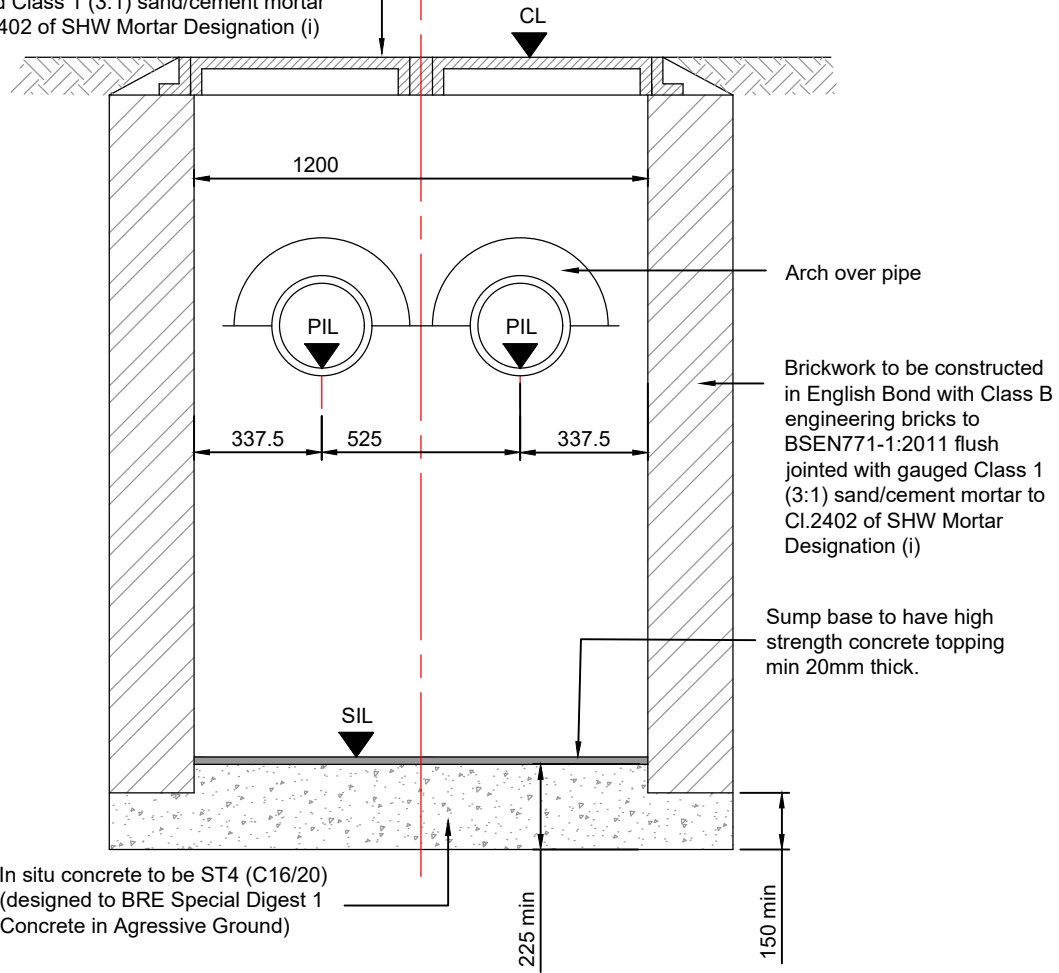

Note: The use of precast rectangular concrete manhole units with 150mm grade ST4 (C16/20) concrete surround (designed to BRE Special Digest 1 Concrete in Aggressive Ground) is permitted.

SW1.1 Manhole Detail

A	Issued For BUDGET/APPROVAL ONLY	04/03/21
REV	DESCRIPTION	DATE

abmh
 ABMH Civils Ltd
 1 The Grove, Felpham, Bognor Regis, West Sussex PO22 7EY
 Mark Mob: 07761 950000
 Email: mark@abmh.co.uk / Web: www.abmh.co.uk

PROJECT	SLINDON POND CHURCH HILL SLINDON, WEST SUSSEX BN18 0RD		
	SW1.1 MH DETAIL		
DRAWING	FC2890/04		
	REV	A	
SCALE	1:20	DATE	FEB 21
	INITIAL	MH	CHKD
			-

This drawing is produced using AutoCAD. Only written dimensions are to be respected.
 © ABMH Civils Ltd - Title to this drawing remains with ABMH Civils Ltd
 Removal of this title block also removes all warranties and infringes copyright.